

B1017-U Flush Valve

Installation Instruction

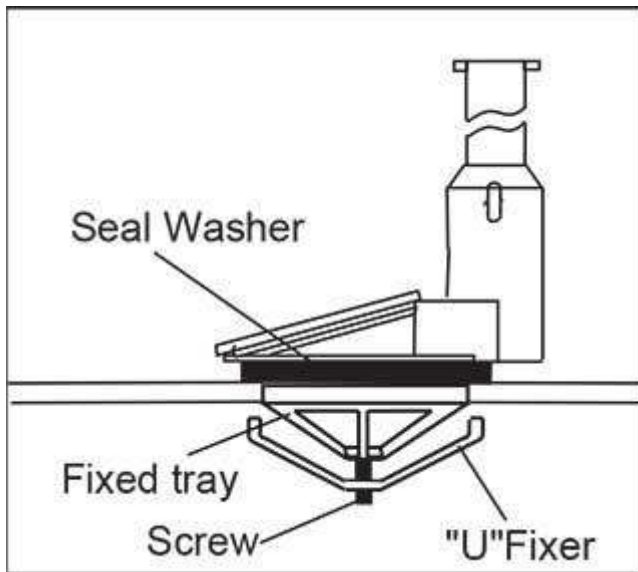

1. Unscrew the "U" fixer,

Put the flush valve into the tank flush hole, and make sure the "U" fixer is put into the tank.

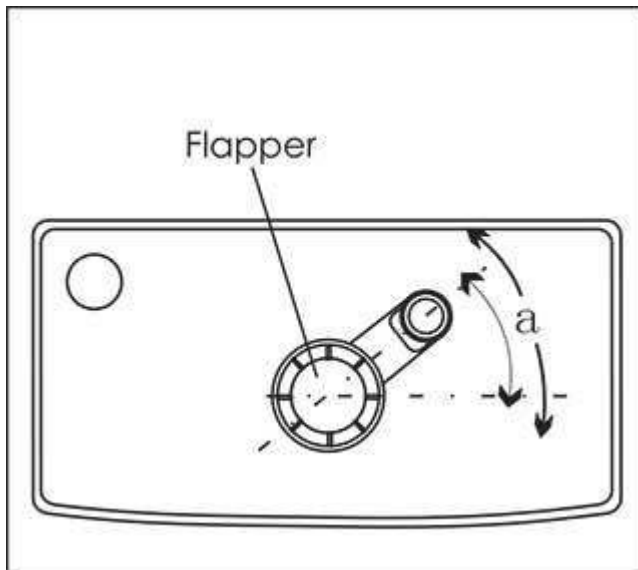

2. Adjust the angle of the flush valve,

make sure the flapper is easy to open, and the chain is not blocked.

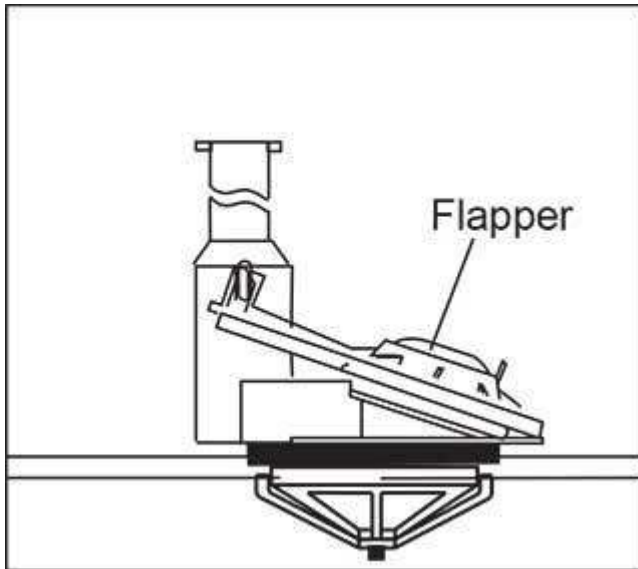

3. Screw the flush valve tight,

and make sure the "U" fixer and seal washer attach on the tank wall. Put the Flapper on the flush valve.

5 Years Warranty for Toilet Tank Fittings:

Subject to the "Exclusions" set forth below, WDI promises to the consumer with the original purchase invoice to repair, or at the option of WDI, to replace, any part of this product which proves to be defective under normal installation and use for 5 years from the date of purchase (the invoice date prevails).

Exclusions: WDI shall not be liable for intentional or any other damages or malfunction resulting from reasons including but not limited to any misuse or inadequate maintenance of the product, or from force majeure. Failure to provide purchase invoice as proof will void this warranty. This warranty is null and void if this defective product can not be attributable to the manufacturer or distributor.